

**26455-35274lbs**  
**CPCD120-160**

**G series Internal Combustion  
Counterbalanced  
Forklift Truck**



**A. Enduring and durable**

- Durable structure design
- Easy and high efficient daily inspection
- Improved protection performance
- Improved cooling efficiency

**B. ENERGY-SAVING**

- High efficient matching, forceful power
- Hydraulic dynamic load variable control system
- Intelligent sensitive thermal management system
- Light type design

**C. COMFORTABLE AND CONVENIENT**

- Easy get on-off
- Smaller turning radius
- Mast lower buffering
- Superior view
- More comfort driving experience

**D. SAFE AND EFFICIENT**

- Better reliability
- OPS (optional)
- Wet type drive axle
- High efficient working

Technical parameters											
Model		CPCD120-C22-09	CPCD135-C22-06	CPCD150-C22-06	CPCD160-C22-06	CPCD140-C22-09	CPCD150-C22-09	CPCD160-C22-09	CPCD140-C22-12	CPCD150-C22-12	CPCD160-C22-12
Rated load	lbs	26455	29762	33069	35274	30865	33069	35274	30865	33069	35274
The mass	lbs	39242	39242	40565	41447	45195	46297	47399	49604	50706	51809
Maximum lifting speed (loaded/unloaded)	ft/min	70.9/78.7	70.9/78.7	68.9/78.7	68.9/78.7	72.8/78.7	72.8/78.7	72.8/78.7	72.8/78.7	72.8/78.7	72.8/78.7
Maximum speed (loaded/unloaded)	mph	15.5/16.8	15.5/16.8	16.2/17.4	16.2/17.4	16.3/17.0	16.3/17.0	16.3/17.0	16.3/17.0	16.3/17.0	16.3/17.0
Gradeability (loaded/unloaded)	%	36.4/40	36.4/40	36.4/40	36.4/40	36.4/40	36.4/40	36.4/40	36.4/40	36.4/40	36.4/40
Noise in the cab	dB(A)	≤73.8	≤73.8	≤73.8	≤73.8	≤73.8	≤73.8	≤73.8	≤73.8	≤73.8	≤73.8
Size parameters											
Overall length	in	264.0	246.3	246.7	246.7	279.7	279.7	279.7	314.0	314.0	314.0
Overall width	in	100.8	100.8	100.8	100.8	100.8	100.8	100.8	100.8	100.8	100.8
Overall height	in	132.5	132.5	133.1	133.1	131.5	131.5	131.5	131.5	131.5	131.5
Load center distance	in	35.4	23.6	23.6	23.6	35.4	35.4	35.4	47.2	47.2	47.2
Wheelbase	in	128.0	128.0	128.0	128.0	137.8	137.8	137.8	147.6	147.6	147.6
Front overhang	in	30.9	30.9	31.3	31.3	36.8	36.8	36.8	36.8	36.8	36.8
Rear overhang	in	33.5	33.5	33.5	33.5	33.5	33.5	33.5	33.5	33.5	33.5
Minimum underground clearance	in	10.2	10.2	9.8	9.8	10.8	10.8	10.8	10.8	10.8	10.8
Seat height	in	77.6	77.6	78.1	78.1	78.1	78.1	78.1	78.1	78.1	78.1
Turning radius (inside)	in	8.7	8.7	8.7	8.7	8.7	8.7	8.7	8.7	8.7	8.7
Turning radius(outside)	in	175.2	175.2	177.2	177.2	187.0	187.0	187.0	200.8	200.8	200.8
Front track	in	74.3	74.3	74.3	74.3	74.6	74.6	74.6	74.6	74.6	74.6
Rear track	in	83.5	83.5	83.5	83.5	83.5	83.5	83.5	83.5	83.5	83.5
Mast height (retracted/extended)	in	132.5/191.5	132.5/191.5	133.1/192.1	133.1/192.1	131.5/190.6	131.5/190.6	131.5/190.6	131.5/190.6	131.5/190.6	131.5/190.6
Mast lifting height	in	118.1	118.1	118.1	118.1	118.1	118.1	118.1	118.1	118.1	118.1
Mast tilting angle (forward/backward)	deg	6/12	6/12	6/12	6/12	6/12	6/12	6/12	6/12	6/12	6/12
Fork dimension (length*width*thickness)	in	71.7x7.9x3.3	53.9x7.9x3.3	53.9x7.9x3.3	53.9x7.9x3.3	71.7x7.9x3.7	71.7x7.9x3.7	71.7x7.9x3.7	96.1x7.9x3.9	96.1x7.9x3.9	96.1x7.9x3.9
Fork adjusting range	in	19.7-93.3	19.7-93.3	19.7-93.3	19.7-93.3	24.0-84.6	24.0-84.6	24.0-84.6	24.0-84.6	24.0-84.6	24.0-84.6

Vehicle configuration											
Truck model		CPCD120-C22-09	CPCD135-C22-06	CPCD150-C22-06	CPCD160-C22-06	CPCD140-C22-09	CPCD150-C22-09	CPCD160-C22-09	CPCD140-C22-12	CPCD150-C22-12	CPCD160-C22-12
Engine	Brand	CUMMINS	CUMMINS	CUMMINS	CUMMINS	CUMMINS	CUMMINS	CUMMINS	CUMMINS	CUMMINS	CUMMINS
	Model	QSB6.7	QSB6.7	QSB6.7	QSB6.7	QSB6.7	QSB6.7	QSB6.7	QSB6.7	QSB6.7	QSB6.7
	Rated power ( Hp/rpm)	175.4/2200	175.4/2200	175.4/2200	175.4/2200	197.1/2300	202.6/2200	202.6/2200	202.6/2200	202.6/2200	202.6/2200
	Rated torque ( lb.ft/rpm)	649.8/1300	649.8/1300	649.8/1300	649.8/1300	590.0/1500	730.2/1300	730.2/1300	730.2/1300	730.2/1300	730.2/1300
	Emission standard	T4F	T4F	T4F	T4F	T4F	T4F	T4F	T4F	T4F	T4F
Transmission	Model	ZF131	ZF131	ZF131	ZF131	ZF171	ZF171	ZF171	ZF171	ZF171	ZF171
Drive axle	Model	Meritor drive axle				Kessler	Kessler	Kessler	Kessler	Kessler	Kessler
Tire	Size	11.00-20	11.00-20	12.00-20	12.00-20	12.00-20	12.00-20	12.00-20	12.00-20	12.00-20	12.00-20
Auxiliary configuration	Backward radar	○	○	○	○	●	●	●	●	●	●
	Backward image	○	○	○	○	●	●	●	●	●	●
	Weighting system	○	○	○	○	○	○	○	○	○	○
	Ops for the whole truck	○	○	○	○	○	○	○	○	○	○
	Ops for mast	○	○	○	○	○	○	○	○	○	○
Hydraulic system	Consistent rate system	●	●	●	●	/	/	/	/	/	/
	Variable system	/	/	/	/	●	●	●	●	●	●
Air conditioner	Air conditioner	●	●	●	●	●	●	●	●	●	●
	Cooler	○	○	○	○	/	/	/	/	/	/
Tyre	Pneumatic tyre	●	●	●	●	●	●	●	●	●	●
	Solid tyre	○	○	○	○	○	○	○	○	○	○
	Solid tyre (front), pneumatic tyre (rear)	○	○	○	○	○	○	○	○	○	○
	Pneumatic tyre (front), solid tyre (rear)	○	○	○	○	○	○	○	○	○	○
Cab	Tilting cab	●	●	●	●	●	●	●	●	●	●

— 29762lbs-23.6  
 — 33069lbs-23.6  
 — 35274lbs-23.6  
 — 26455lbs-35.4  
 — 30865lbs-35.4  
 — 33069lbs-35.4  
 — 35274lbs-35.4  
 — 30865lbs-47.2  
 — 33069lbs-47.2  
 — 35274lbs-47.2

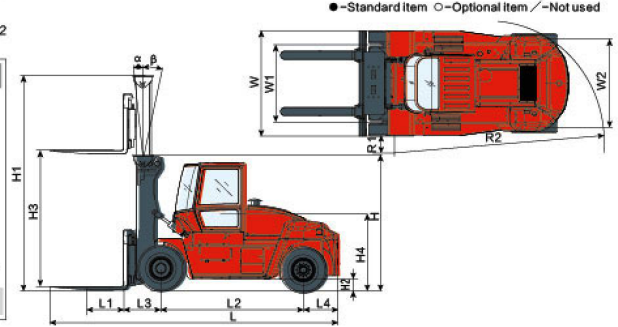
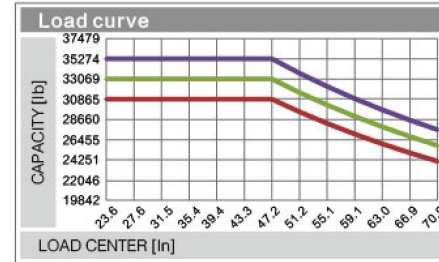
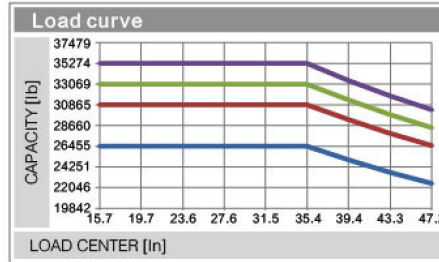
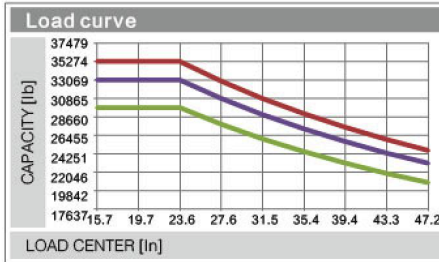

\* Our products are subject to improvements and changes without notice.