

General Description Of The Company

Anhui Forklift Group Corporation Ltd. (hereinafter referred as Heli) is a leading enterprise of industrial trucks in China.

Since 2016, Heli has been ranked among the top seven in the world, representing Chinese brands to forge ahead towards higher stage. (According to the "Top 20 Industrial lift truck suppliers" released by MMH.)

As the leading enterprise in China industrial truck industry, Heli has the ability and strength to participate in the global competition in a higher level, larger scale and wider field. Heli has established overseas centers in France, Thailand and the United States, which enhance the service ability in overseas market. Besides, relying on our global partners, we have established an overseas marketing and service network in more than 80 countries and regions, and Heli products are sold to more than 150 countries and regions in the world. In the next five years, Heli will vigorously promote the international operation and create a global famous brand.



**CPD15/16/
18/20 SQ**
GE1LI/GE2LI



LITON **3000-4000 lbs**
G3 series Three-wheel Lithium Battery
Forklift Truck (Double Drive)

* Details of specifications and equipment are based on information available at time of printing and may change without notice.

4320 NW 72 Ave, 33166 Miami, Florida – USA
(786) 340-6550 - sales@heliforklift-florida.com

HELI

COMPACT IN SIZE

BIG ON PERFORMANCE



POWERFUL LITHIUM-ION
TECHNOLOGY

Higher Performance, Quicker Working Efficiency

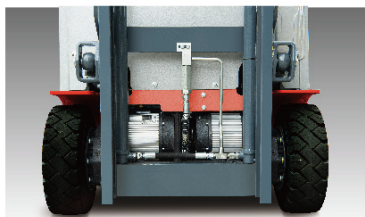

Front wheel dual drive motors provide more power.

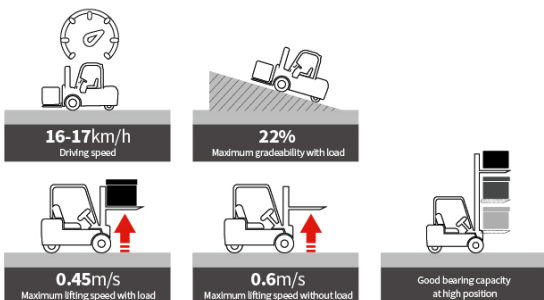

Fast Charging For Long Battery Life



Be equipped with full hydraulic priority steering system, supply oil on demand, reduce vehicle energy consumption

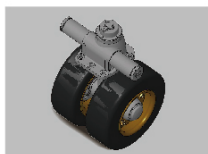

High precision angle potentiometer makes steering more sensitive and accurate.



LED light of the whole truck has high brightness, long life and is more energy saving.



Low rolling resistance electric truck special solid tire reduces driving resistance consumption.

Small Dimension, More Flexible

- Narrow truck width is more suitable for narrow aisle application;
- Large angle steering axle makes the turning radius smaller satisfying the loading and unloading operation in narrow aisle.



High Efficient Fast Charging, Ultra Long Endurance

- Realizes faster charging; standard 202ah lithium battery has ultra long endurance;
- The high density energy and fast charging characteristics of lithium battery make it possible to carry out full time operation without interruption.

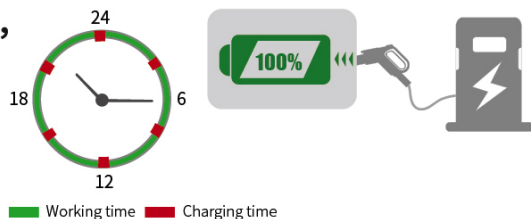

Enjoyable Driving Experience



CURTIS Display



FJ Display

- P — Powerful
 - E — Economical
 - S — Energy-saving
- Multi-gear performance mode can adapt to a variety of working conditions at will.

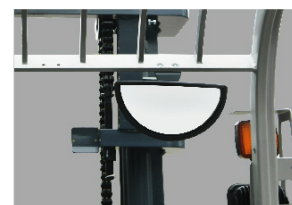

Middle rearview mirror



Parking system



USB power supply



Storage box



Wide view mast



Enough space

Intelligent Security Protection

- **Intelligent stabilization system:** It can automatically adjust the tilt angle and speed of the mast according to the lifting height and load state. Improve the high bearing capacity and vehicle stacking safety;
- **Intelligent speed limit in different application:** multi-scenario identification and intelligent speed limit balance efficiency and safety;
- **Intelligent limit buffering:** intelligent induction of mast lifting and lowering avoids extreme impact and is safe and comfortable;
- **Intelligent operation protection:** a full set of OPS system can avoid misoperation and ensure safety;
- **Intelligent control strategy:** dual core controller is in line with the latest EU safety requirements.
- **Intelligent steering deceleration:** the automatic deceleration function of the turning can reduce the risk of turning over;
- **Lithium battery which heats itself automatically at low temperatures** has excellent low temperature adaptability.

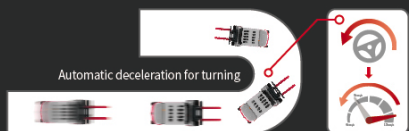
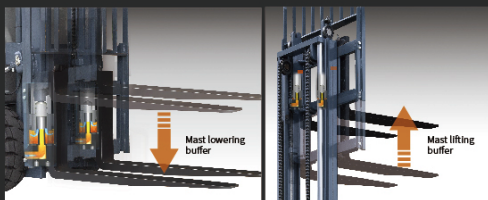
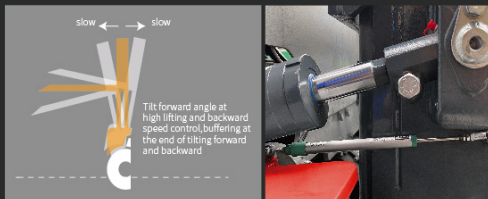

Reliable, Superb Quality, Easy to Maintain

- This forklift can work in cold storage at minus 20 degrees Celsius. And the reinforced cast steering axle and the mast of optimized design ensure safety.

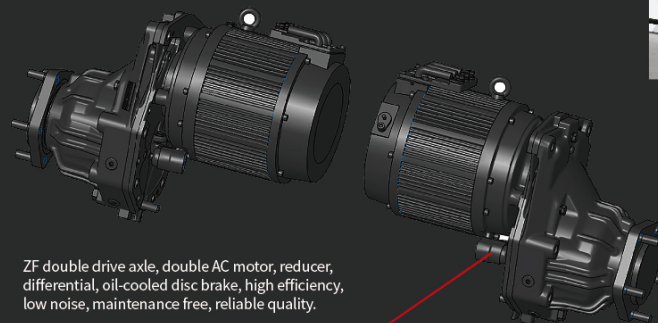

Operating Cost Comparison:

Lithium battery forklift vs. Lead-acid battery forklift vs. IC forklift

The advantages of HELI lithium battery forklift trucks are more prominent in the life cycle cost. Compared with internal combustion forklift truck, lithium battery forklift truck has the advantages of no noise, no pollution, small vibration and simple operation. Compared with the lead-acid battery forklift truck, lithium battery forklift has the characteristics of fast charging and charging at any time, which is more suitable for multi shift operation. Besides, HELI lithium battery forklift is maintenance free, high power conversion efficiency, and economical overall operation cost.

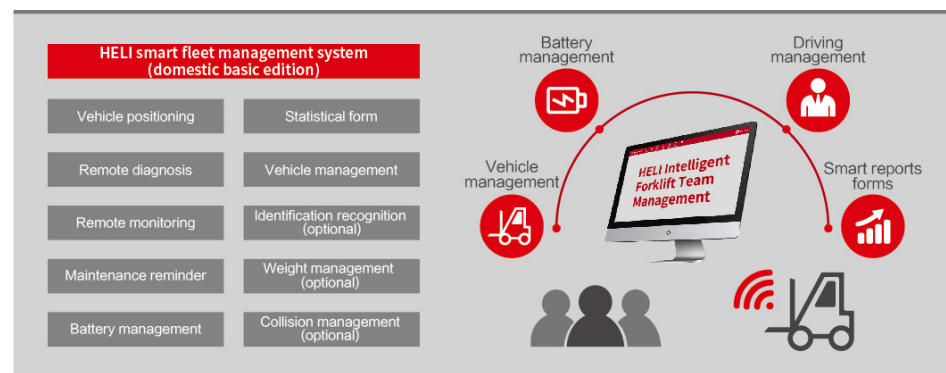
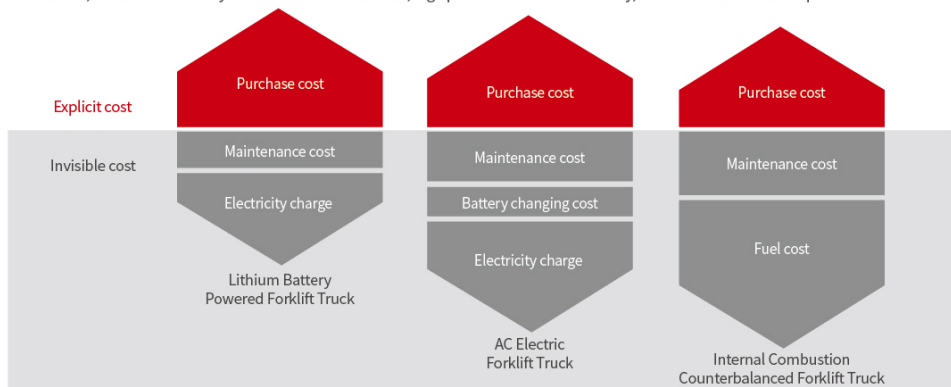

Manufacturer and Technical Data						
Characteristics						
1.01	Manufacturer		HELI			
1.02	Model		CPD15SQ	CPD16SQ	CPD18SQ	CPD20SQ
1.03	Configuration number		GE1LI/GE2LI	GE1LI/GE2LI	GE1LI/GE2LI	GE1LI/GE2LI
1.04	Rated capacity	lbs	3000	3200	3500	4000
1.05	Load center distance	in	24	24	24	24
1.06	Power mode		Lithium Battery			
1.07	Driving mode		Seated			
1.08	Load distance, center of drive axle to fork	in	14.4	14.4	14.4	14.6
1.09	Wheelbase	in	50.9	50.9	55.1	55.1
Weight						
2.01	Total weight (with/without battery)	lbs	6380/5764	6457/5841	7095/6480	7341/6724
Tyres						
3.01	Tyre type		SE	SE	SE	SE
3.02	Tyre size, front		18x7-8	18x7-8	200/50-10	200/50-10
3.03	Tyre size, rear		140/55-9	140/55-9	16X6-8	16X6-8
3.04	Wheels, number front/rear (x=driven wheels)		2x/2	2x/2	2x/2	2x/2
3.05	Tread, front	in	36.2	36.2	36.5	36.5
3.06	Tread, rear	in	7.8	7.8	9.8	9.8
Dimensions						
4.01	Height of overhead guard	in	80.3	80.3	80.3	80.3
4.02	Height of seat	in	41.2	41.2	41.9	41.9
4.03	Overall length (with/without fork)	in	112.2/76	112.2/76	116.9/80.9	116.9/80.9
4.04	Overall width	in	41.7/42.4	41.7/42.4	41.7/44.1	41.7/44.1
4.05	Ground clearance (laden, between mast)	in	3.5	3.5	3.5	3.5
4.06	Ground clearance (center of wheelbase)	in	3.9	3.9	3.9	3.9
4.07	Min. outside turning radius	in	60.8	60.8	65.9	65.9
Performance Data						
5.01	Travel speed (laden/unladen)	mph	10/10.6	10/10.6	10/10	10/10
5.02	Lift speed (laden/unladen)	fpm	88.6/127.9	88.6/127.9	80.7/118.1	78.7/118.1
5.03	Lowering speed (laden/unladen)	fpm	114.2/98.4	114.2/98.4	114.2/98.4	114.2/98.4
5.04	Max. gradeability (laden/unladen)	%	22/30	22/30	22/30	22/30
Battery						
6.01	Battery voltage/Capacity	V/Ah	80/202	80/202	80/202	80/202
Motor and controller						
7.01	Driving motor powering (S2-60min)	HP	7.7x2	7.7x2	7.7x2	7.7x2
7.02	Lifting motor powering (S3-15%)	HP	18.8	18.8	18.8	18.8
7.03	Driving motor controlling mode		MOSFET/AC			
7.04	Lifting motor controlling mode		MOSFET/AC			
Addition data						
8.01	Service brake/Parking brake		Hydraulic/Hydraulic			

Note: For configuration number, 1: CURTIS Controller; 2: ZAPI Controller;

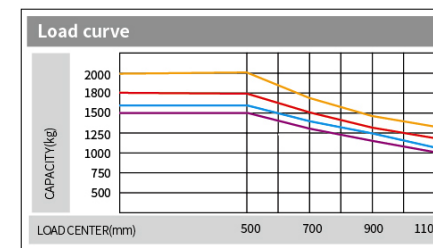
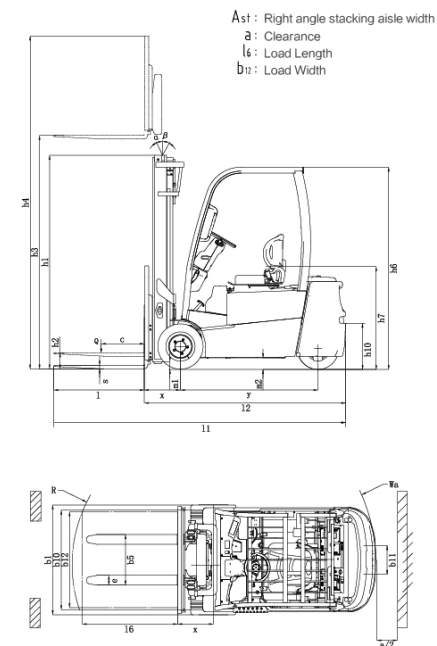

CPD15SQ CPD16SQ CPD18SQ CPD20SQ

Note: The vertical axis stands for load capacity and the horizontal axis stands for load center which is calculated from the front surface of the forks to the gravity of the standard load. The standard load means a cubic with 1000mm edge length. When mast is tilted forward, using non-standard forks or loading large goods, the load capacity will be reduced. The load capacity of standard mast at different load center can be known from this load chart.

WIDE VIEW MAST											
Mast model	Max.lifting height (in/mm)	Load capacity (load center 500mm)(lbs/kg)				Mast overall height (fork to the ground) (in/mm)	Service weight (lbs)				Mast tilting angle (°) α/β
		CPD15SQ	CPD16SQ	CPD18SQ	CPD20SQ		CPD15-20SQ	CPD15SQ	CPD16SQ	CPD18SQ	
M200	79/2000	3000/1362	3200/1454	3500/1589	4000/1816	60/1525	6222	6299	6917	7149	5/7
M250	98/2500	3000/1362	3200/1454	3500/1589	4000/1816	69.9/1775	6281	6358	6998	7229	5/7
M300	118/3000	3000/1362	3200/1454	3500/1589	4000/1816	79.7/2025	6345	6400	7060	7291	5/7
M330	130/3300	3000/1362	3200/1454	3500/1589	4000/1816	85.6/2175	6380	6457	7095	7341	5/7
M350	138/3500	3000/1362	3200/1454	3500/1589	4000/1816	89.6/2275	6402	6470	7119	7350	5/7
M370	146/3700	3000/1362	3200/1454	3500/1589	4000/1816	93.5/2375	6428	6483	7143	7374	5/7
M400	157/4000	3000/1362	3200/1454	3500/1589	4000/1816	101.4/2575	6523	6578	7238	7469	3/5
M425	167/4250	3000/1362	3200/1454	3500/1589	3630/1650	106.3/2700	6615	6673	7333	7564	3/5
M450	177/4500	2750/1250	2860/1300	3300/1500	3630/1650	111.2/2825	6651	6706	7366	7597	3/5
M500	197/5000	2530/1150	2750/1250	3080/1400	3300/1500	121.1/3075	6719	6774	7434	7665	3/5
M550	217/5500	2090/950	2310/1050	2750/1250	2750/1250	132.9/3375	6846	6901	7531	7792	3/3
M600	236/6000	1540/700	1760/800	1870/850	2090/950	142.7/3625	6915	6970	7630	7861	3/3

WIDE VIEW FULL FREE 2-STAGE MAST												
Mast model	Max.lifting height (in/mm)	Load capacity (load center 500mm)(lbs/kg)				Mast overall height (fork to the ground) (in/mm)	Free lifting height (with backrest) (in/mm)	Service weight (lbs)				Mast tilting angle (°) α/β
		CPD15SQ	CPD16SQ	CPD18SQ	CPD20SQ			CPD15-20SQ	CPD15-20SQ	CPD15SQ	CPD16SQ	
ZM200	79/2000	3000/1362	3200/1454	3500/1589	4000/1816	60/1525	20.1/510	6281	6358	7000	7117	5/7
ZM250	98/2500	3000/1362	3200/1455	3500/1589	4000/1816	69.9/1775	29.9/760	6345	6422	7060	7181	5/7
ZM300	118/3000	3000/1362	3200/1456	3500/1589	4000/1816	79.7/2025	39.8/1010	6406	6461	7121	7242	5/7
ZM330	130/3300	3000/1362	3200/1457	3500/1589	4000/1816	85.6/2175	45.7/1160	6446	6523	7161	7260	5/7
ZM350	138/3500	3000/1362	3200/1458	3500/1589	4000/1816	89.6/2275	49.6/1260	6470	6540	7185	7306	5/7
ZM370	146/3700	3000/1362	3200/1459	3500/1589	4000/1816	93.5/2375	53.5/1360	6501	6556	7216	7381	5/7
ZM400	157/4000	3000/1362	3200/1460	3500/1589	4000/1816	101.4/2575	61.4/1560	6600	6655	7315	7436	3/5

WIDE VIEW FULL FREE 3-STAGE MAST												
Mast model	Max.lifting height (in/mm)	Load capacity (load center 500mm)(lbs/kg)				Mast overall height (fork to the ground) (in/mm)	Free lifting height (with backrest) (in/mm)	Service weight (lbs)				Mast tilting angle (°) α/β
		CPD15SQ	CPD16SQ	CPD18SQ	CPD20SQ			CPD15-20SQ	CPD15-20SQ	CPD15SQ	CPD16SQ	
ZSM360	142/3600	3000/1362	3200/1460	3500/1589	4000/1816	70.5/1790	30.7/781	6697	6774	7412	7753	3/5
ZSM400	157/4000	3000/1363	3200/1460	3500/1589	4000/1816	75.8/1925	36.1/916	6752	6829	7467	7808	3/5
ZSM435	171/4350	3000/1364	2860/1300	3300/1500	3630/1650	80.3/2040	40.6/1031	6813	6890	7528	7869	3/5
ZSM450	177/4500	2750/1250	2860/1300	3300/1500	3630/1650	82.3/2090	42.6/1081	6838	6915	7553	7894	3/5
ZSM470	185/4700	2640/1200	2750/1250	3190/1450	3410/1550	85/2160	45.3/1151	6873	6950	7581	7922	3/5
ZSM480	189/4800	2640/1200	2750/1250	3190/1450	3410/1550	86.2/2190	46.5/1181	6884	6961	7592	7933	3/5
ZSM500	197/5000	2310/1050	2530/1150	3080/1400	3300/1500	90.1/2290	50.4/1281	6932	7009	7641	7982	3/5
ZSM540	213/5400	1980/900	2200/1000	2420/1100	2750/1250	95.5/2425	55.7/1416	7055	7132	7764	8105	3/3
ZSM600	236/6000	1540/700	1760/800	1870/850	2090/950	103.9/2640	64.2/1631	7143	7220	7852	8193	3/3
ZSM650	256/6500	1320/600	1540/700	1760/800	1870/850	111.4/2830	71.7/1821	7236	7313	7944	8285	3/3

LITHIUM BATTERY CHARGER					
Lithium battery brand	HELI		CATL		EIKTO
Voltage/Capacity	80V/202	80V/271	80V/202	80V/271	80V/271
CPD15/16/18/20SQ	●	○	○	○	○
Low temperature heating of lithium battery	●				
Charger	D80V200ALI-123 D80V200ALI-423				
Note: ● standard ○ optional — non-configurable					

Optional			
Security class	Steering automatic deceleration	●	
	Reversing handle with horn button	●	
	OPS system(Excluding descent)	●	
	Complete OPS system	○	
	Seat belt switch	●	
	Multi way valve overload	●	
	Fire extinguisher	○	
	Backward buzzer	●	
	Reversing Chinese language horn	○	
	Electronic upper buffer	●	
	Rearview mirror with angle in the middle	●	
	Left and right rear mirror	○	
Comfort class	Tilt speed limit	●	
	Active stabilization (standard configuration for full free 3-stage mast above 4m)	●	
	Standard seat	●	
	Fully suspended seat	○	
	USB power	●	
	Mechanical valve	●	
	Solenoid valve (proportional valve + thumb switch)	○	
	Fan	○	
	Color screen instrument	●	
	Heater	○	
	Performance mode control	●	
	Non standard overhead guard	Steering wheel with operation ball	●
Steering wheel without operation ball		○	
The height of overhead guard is increased by 50mm		○	
Overhead guard with protective net		○	
Cab/windshield glass		Cab	○
		Fit the front windshield	○
		Equipped with rear windshield	○
		Equipped with top rain glass	○
		No rear work lights or rear blue lights	●
		LED rear work light	○
Light class		LED rear blue light (without switch control)	○
		led rear work light and led rear blue light (without switch control)	○
	LED flickering warning light	●	
	LED rotary warning light	○	
	Led rotary buzzer warning light	○	
	Other	HEDING lithium battery	●
		ENEROC lithium battery	○
		EIKTO lithium battery	○
		Solid tire	●
		Traceless tyre	○
		Single tire (front wheel)	●
		Double tire (front wheel)	-
Metric thread		●	
American thread		○	
Sleeve for Tilting cylinder		○	
Tilting cylinder,sleeve for steering cylinder		○	
HELI package		●	
Neutral package	○		
Chinese sticker	●		
English sticker	○		
Custom-made sticker	○		
HELI smart fleet management system(standard version)	○		

Note: ● standard ○ optional — non-configurable