

2-3.5 t **LIION**

**G series Lithium Battery Powered
Counterbalanced Forklift
Truck (UPGRADED)**



G SERIES 2-3.5 t LITHION

wide view



Widened solid tire



IPX4 waterproof grade



Environment Friendliness

- > Zero emission
- > Low noise
- > Free of heavy metals
- > No corrosion
- > No acid mist volatilization

Maintenance Free

- > Unnecessary of fluid adding and dust proofing
- > Daily maintenance free
- > Manual maintenance free

Long Service Life

- > Over 75% capacity reserved after 4000 shifts operation
- > Longer service life than lead-acid battery in equal working condition
- > 5 years or ten thousand hours quality guarantee for high performance lithium battery assembly

High Efficiency and Energy Saving

- > 1-2hours charging meet 6-8 hours working demand
- > High-energy density, self discharging rate lower than 1% per month
- > 95% energy conversion rate, superior charging and discharging performance
- > Flexible to charge, easy to operate, no impact on battery life
- > Unnecessary to change battery, cost saving



Full LED lights



Standard USB interface



↑ Suitable for working in both high and low environment

- › Lithium battery is better than lead-acid battery when working between -25°C and 55°C

↑ High Safety

- › According to the characteristics of industrial vehicles, it achieves
- › safety protection design which includes lithium battery materials,
- › battery core type, pack technique and system power management
- › "Multiple node safety closed circuit protection" realizing truck real time closed circuit protection in variable conditions
- › "Lock affirming" function during charging avoiding "hot connecting and disconnecting" operation effectively
- › "Whole system emergency button" to disconnect the truck control system and bms power quickly ensuring truck safety

The superiority of HELI lithium battery forklift truck is embodied in the use-cost within product lifecycle. Compared with lead-acid battery forklift truck, lithium battery forklift truck is more convenient for multiple working shifts. It has lower implicit cost and more economical total running cost.

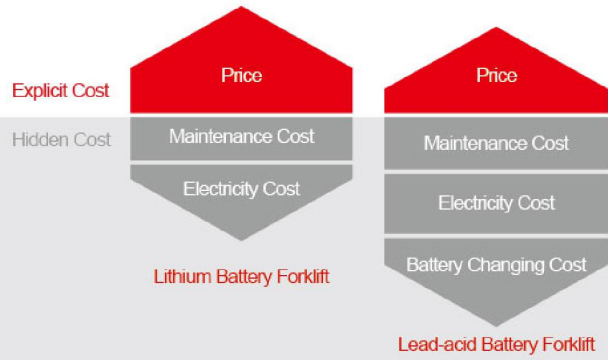

Manufacturer's Data and Design Characteristics

Characteristics					
1.01	Manufacturer			HELI	
1.02	Model			CPD20	CPD25
1.03	Configuration Number			GB2Li	GB2Li
1.04	Rated Capacity	Q	kg	2000	2500
1.05	Load Center Distance	c	mm	500	500
1.06	Power Mode			lithium battery	lithium battery
1.07	Driving Mode			seated	seated
1.08	Wheel Base	L1	mm	1550	1550
Tyre					
2.01	Tyre Type			pneumatic tyre	pneumatic tyre
2.02	Wheels, Number Front Rear (X=Driven Wheels)			2/2	2/2
2.03	Front Wheel Base	W3	mm	960	960
2.04	Rear Wheel Base	W2	mm	950	950
2.05	Tyre (Front)			23×9-10-16PR	23×9-10-16PR
2.06	Tyre (Rear)			18×7-8-14PR	18×7-8-14PR
Size					
3.01	Front Overhang	L2	mm	425	425
3.02	Mast Tilt Angle, Front/Rear	α/β	°	6/8	6/8
3.03	Height With Mast Retraction	H1	mm	1995	1995
3.04	Free Lifting Height	H3	mm	145	145
3.05	Max. Lifting Height	H	mm	3000	3000
3.06	Mast Height, Extended	H2	mm	4042	4042
3.07	Overhead Guard Height	H4	mm	2150	2150
3.08	Fork Size: Thickness×Width×Length	T×W×L4	mm	40×122×920	40×122×1070
3.09	Fork Carriage, Din Standard			2A	2A
3.10	Truck Body Length (Fork Excluded)	L'	mm	2270	2280
3.11	Truck Body Width	W1	mm	1185	1185
3.12	Turning Radius	r	mm	2000	2010
3.13	Clearance Between Mast And Ground	H5	mm	110	110
3.14	Clearance Between Wheel Base Center And Ground (Loaded)	H6	mm	115	115
3.15	Right Angle Stacking Aisle Width (Pallet1000x1000mm, Clearance 200mm)	Ast	mm	3625	3635
3.16	Right Angle Stacking Aisle Width (Pallet1200x1200mm, Clearance 200mm)	Ast	mm	3825	3835
3.17	Lateral Fork Adjustment(Outside Of Forks)max./min.	W5	mm	1030/244	1030/244
Performance					
4.01	Travelling Speed: Loaded/Unloaded		km/h	16/16	16/16
4.02	Lifting Speed: Loaded/u/Unloaded		mm/s	350/510	330/510
4.03	Lowering Speed: Loaded/Unloaded		mm/s	450/500	450/500
4.04	Gradeability (Loaded)		%	22	20
4.05	Max. Traction Force (Loaded)		N	16000	16500
4.06	Acceleration Time (10m) Loaded/Unloaded		s	4.6/4.4	4.6/4.4
Weight					
5.01	Total Weight (With /Without Battery)		kg	3620/3340	3910/3630
5.02	Axle Load: Unloaded, Front/Rear		kg	1493/2127	1690/2220
5.03	Axle Load: Loaded, Front/Rear		kg	4687/933	5680/730
Battery					
6.01	Battery Voltage/Capacity (Discharging Capacity In 5 Hours)		V/Ah	80/271	80/271
6.02	Battery Weight		kg	280	280
Motor And Controller					
7.01	Driving Motor Power (S2-60min)		kW	12	12
7.02	Lifting Motor Power (S3-15%)		kW	15	15
7.03	Drive Motor Controlling Mode			MOSFET/AC"	MOSFET/AC"
7.04	Lifting Motor Controlling Mode			MOSFET/AC"	MOSFET/AC"
Others					
8.01	Service Brake/Parking Brake			hydraulic/mechanical"	hydraulic/mechanical"
8.02	Hydraulic System Working Pressure		Mpa	17.5	17.5
8.03	Type Of Drive Control			ZAPI	ZAPI

NTOE: For configuration number, 2: ZAPI Controller; 3: INMOTION Controller;

Manufacturer's Data and Design Characteristics

Characteristics				
1.01	HELI			
1.02	CPD30	CPD30	CPD35	CPD35
1.03	GB2Li	GB3Li	GB2Li	GB3Li
1.04	3000	3000	3500	3500
1.05	500	500	500	500
1.06	lithium battery	lithium battery	lithium battery	lithium battery
1.07	seated	seated	seated	seated
1.08	1715	1715	1715	1715
Tyre				
2.01	pneumatic tyre/solid	pneumatic tyre/solid	solid tyre	solid tyre
2.02	2/2	2/2	2/2	2/2
2.03	1000	1000	1000	1000
2.04	990	990	990	990
2.05	28×9-15-12PR	28×9-15-12PR	28×9-15	28×9-15
2.06	200/50-10	200/50-10	200/50-10	200/50-10
Size				
3.01	485	485	490	490
3.02	6/10	6/10	6/10	6/10
3.03	2075	2075	2180	2180
3.04	145	145	150	150
3.05	3000	3000	3000	3000
3.06	4230	4230	4230	4230
3.07	2215	2215	2215	2215
3.08	45×125×1070	45×125×1070	50×125×1070	50×125×1070
3.09	3A	3A	3A	3A
3.10	2525	2525	2550	2550
3.11	1245	1245	1245	1245
3.12	2240	2240	2260	2260
3.13	135	135	135	135
3.14	145	145	145	145
3.15	3995	3995	4020	4020
3.16	4125	4125	4150	4150
3.17	1060/250	1060/250	1060/250	1060/250
Performance				
4.01	17/18	17/18	16.5/17.5	16.5/17.5
4.02	340/460	340/460	325/450	325/450
4.03	-/500	-/500	-/500	-/500
4.04	18	18	15	15
4.05	21700	21700	21700	21700
4.06	4.7/4.5	4.7/4.5	4.9/4.7	4.9/4.7
Weight				
5.01	4490/4030	4490/4030	5100/4640	5100/4640
5.02	2095/2395	2095/2395	2290/2810	2290/2810
5.03	6820/670	6820/670	7810/790	7810/790
Battery				
6.01	80/404	80/404	80/404	80/404
6.02	420	420	420	420
Motor And Controller				
7.01	16.6	16.6	16.6	16.6
7.02	13.5	13.5	13.5	13.5
7.03	MOSFET/AC"	MOSFET/AC"	MOSFET/AC"	MOSFET/AC"
7.04	MOSFET/AC"	MOSFET/AC"	MOSFET/AC"	MOSFET/AC"
Others				
8.01	hydraulic/mechanical"	hydraulic/mechanical"	hydraulic/mechanical"	hydraulic/mechanical"
8.02	21	21	21	21
8.03	ZAPI	INMOTION	ZAPI	INMOTION

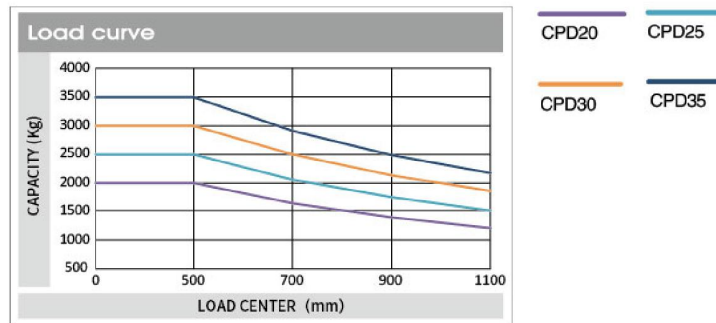
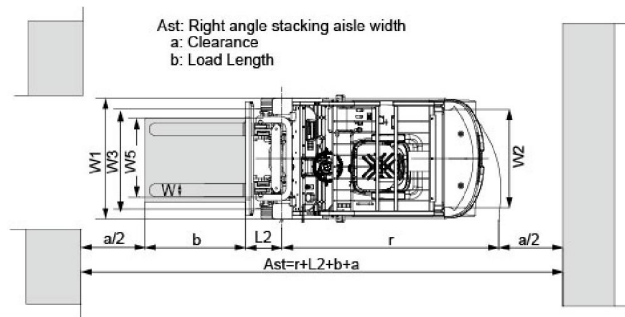
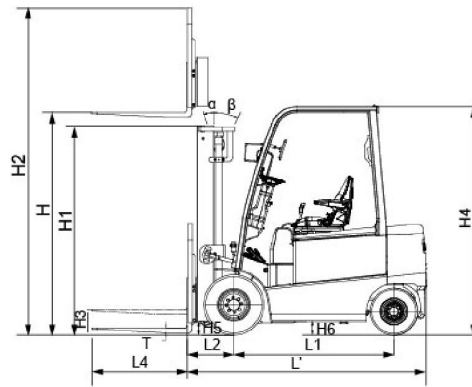

Note: The vertical axis stands for load capacity and the horizontal axis stands for load center which is calculated from the front surface of the forks to the gravity of the standard load. The standard load means a cubic with 1000mm edge length. When mast is tilted forward, using non-standard forks or loading large goods, the load capacity will be reduced. The load capacity of standard mast at different load center can be known from this load chart.

LITHIUM BATTERY				
Model	Configuratio	Voltage(V)	Capacity(Ah)	Supplier
CPD20/CPD25	Standard	80	271	ENEROC
	Optional	80	404	ENEROC
CPD30/CPD35	Standard	80	404	ENEROC
	Optional	80	542	ENEROC

WIDE VIEW MAST

Mast model	Max. lifting height (mm)	Load capacity (load center 500mm) (kg)					Mast overall height (to the ground) (mm)					Mast tilt angle (α/β) (°)					Weight (kg)				
		2t	2.5t	3t	3.5t	3.5t	2-2.5t	3t	3.5t	3.5t	2-2.5t	3t	3.5t	2-2.5t	3-3.5t	2t	2.5t	3t	3.5t		
M200	2000	2000	2500	3000	3500	3500	1495	1570	1680	1680	6/8	6/8	6/10	6/10	3530	3820	4395	5000			
M250	2500	2000	2500	3000	3500	3500	1745	1820	1930	1930	6/8	6/8	6/10	6/10	3575	3865	4435	5050			
M300	3000	2000	2500	3000	3500	3500	1995	2070	2180	2180	6/8	6/8	6/10	6/10	3620	3910	4480	5100			
M350	3500	2000	2500	3000	3500	3500	2145	2220	2330	2330	6/8	6/8	6/10	6/10	3665	3955	4520	5150			
M370	3700	2000	2500	3000	3500	3500	2245	2320	2430	2430	6/8	6/8	6/10	6/10	3685	3975	4570	5160			
M400	4000	2000	2500	3000	3500	3500	2845	2820	2730	2730	6/5	6/5	6/6 8/10	6/6 8/10	3745	4035	4635	5245			
M450	4500	2000	2500	3000	3500	3500	3350	2870	2745	2855	6/5	6/5	6/6 8/10	6/6 8/10	3765	4055	4660	5270			
M500	5000	1800	1950 2050	2400 2550	2650 2800	2800	2795	2795	2680	2980	6/5	6/5	6/6 8/10	6/6 8/10	3790	4080	4685	5295			
M550	5500	1400	1550 1950	2250 2450	2500 2800	2800	3345	3420	3330	3120	3/3 8/5	3/3 8/5	3/6 8/6	3/6 8/6	3915	4125	4735	5345			
M600	6000	950 1500	1100 1800	1500 2200	1550 2400	2400	3595	3670	3780	3590	3/3 8/5	3/3 8/5	3/6 8/6	3/6 8/6	3960	4250	4815	5480			

Note: (1) *refers to rated capacity with dual front lines or wider lines;

WIDE VIEW FULL FREE 2-STAGE MAST

Mast model	Max. lifting height (mm)	Load capacity (load center 500mm) (kg)					Mast overall height (mm)					Free lifting height (with backrest) (mm)					Mast tilt angle (α/β) (°)					Weight (kg)				
		2t	2.5t	3t	3.5t	3.5t	2-2.5t	3t	3.5t	3.5t	2-2.5t	3t	3.5t	2-2.5t	3-3.5t	2t	2.5t	3t	3.5t							
ZM200	2000	2000	2500	3000	3500	3500	1495	1570	1680	1680	447	380	500	6/8	6/8	6/10	6/10	3540	3830	4436	5066					
ZM250	2500	2000	2500	3000	3500	3500	1745	1820	1930	1930	697	630	750	6/8	6/8	6/10	6/10	3590	3880	4480	5110					
ZM300	3000	2000	2500	3000	3500	3500	1995	2070	2180	2180	947	880	1000	6/8	6/8	6/10	6/10	3635	3925	4526	5155					
ZM350	3500	2000	2500	3000	3500	3500	2145	2220	2330	2330	1097	1030	1150	6/8	6/8	6/10	6/10	3685	3965	4533	5182					
ZM370	3700	2000	2500	3000	3500	3500	2245	2320	2430	2430	1197	1130	1250	6/8	6/8	6/10	6/10	3685	3975	4571	5200					
ZM400	4000	2000	2500	3000	3500	3500	2845	2820	2730	2730	1497	1430	1550	6/5	6/5	6/6 8/10	6/6 8/10	3765	4055	4661	5292					
ZM450	4500	2000	2500	3000	3500	3500	3350	2870	2745	2855	1622	1555	1675	6/5	6/5	6/6 8/10	6/6 8/10	3790	4080	4683	5314					
ZM450	4500	1900	2300	2750	3100	3100	2795	2870	2980	2980	1747	1675	1800	6/5	6/5	6/6 8/10	6/6 8/10	3815	4105	4706	5337					
ZM500	5000	1800	1950 2050	2400 2550	2650 2800	2800	3045	3120	3230	3230	1937	1830	2050	6/5 8/6	6/5 8/6	6/6 8/6	6/6 8/6	3865	4155	4751	5382					
ZM550	5500	1400	1550 1950	2250 2450	2500 2800	2800	3345	3420	3530	3530	2297	2230	2350	3/3 8/5	3/3 8/5	3/6 8/6	3/6 8/6	3945	4235	4841	5474					
ZM600	6000	950 1500	1100 1800	1500 2200	1550 2400	2400	3595	3670	3780	3780	2547	2480	2600	3/3 8/5	3/3 8/5	3/6 8/6	3/6 8/6	3995	4295	4888	5520					

Note: (1) *refers to rated capacity with dual front lines or wider lines;
 (2) 2.2.5t: free lifting height 397mm increase without backrest ;
 (3) 3.3.5t: free lifting height 399mm increase without backrest ;

三级全自由门架 WIDE VIEW FULL FREE 3-STAGE MAST

Mast model	Max. lifting height (mm)	Load capacity (load center 500mm) (kg)					Mast overall height (mm)					Free lifting height (with backrest) (mm)					Mast tilt angle (α/β) (°)					Weight (kg)				
		2t	2.5t	3t	3.5t	3.5t	2-2.5t	3-3.5t	2-2.5t	3t	3.5t	2-2.5t	3t	3.5t	2-2.5t	3-3.5t	2t	2.5t	3t	3.5t						
ZSM360	3600	2000	2500	3000	3400	3400	1975	1930	774	740	745	6/8	6/6	6/6	6/6	3780	4070	4745	5355							
ZSM400	4000	2000	2500	2900	3350	3350	1920	2055	900	865	870	6/5	6/5	6/6	6/6	3815	4105	4780	5360							
ZSM435	4350	2000	2450	2750	3150	3150	2045	2180	1024	990	995	6/5	6/5	6/6	6/6	3850	4140	4815	5365							
ZSM450	4500	2000	2300	2700	3000	3000	2095	2230	1074	1040	1045	6/5	6/5	6/6	6/6	3865	4155	4831	5411							
ZSM470	4700	2000	2200	2700	2900	2900	2160	2230	1140	1140	1048	6/5	6/5	6/6	6/6	3880	4170	4835	5415							
ZSM480	4800	1900	2050	2600	2800	2800	2195	2330	1174	1140	1145	6/5	6/5	6/6	6/6	3890	4180	4860	5440							
ZSM500	5000	1800	1950 2050	2400 2500	2650	2650	2295	2430	1274	1240	1245	6/5 8/5	6/5 8/5	6/6 8/6	6/6 8/6	3920	4210	4889	5469							
ZSM540	5400	1400	1550 1950	2250 2450	2500	2500	2420	2555	1400	1365	1370	3/3 8/5	3/3 8/6	3/6 8/6	3/6 8/6	3960	4250	4924	5504							
ZSM600	6000	950 1500	1100 1800	1550 2150	1550 2300	2300	2645	2780	1624	1624	1590	3/3 8/5	3/3 8/6	3/6 8/6	3/6 8/6	4025	4315	5023	5603							
ZSM650	6500	700 1400	800 1600	1250 2200	1300 2500	2500	2835	2970	1814	1788	1793	3/3 8/5	3/3 8/5	3/3 8/6	3/3 8/6	4055	4345	5076	5656							
ZSM700	7000	300 1100	400 1200	850 2100	1000 2300	2300	3105	3240	2084	2058	2063	3/3 8/5	3/3 8/5	3/3 8/6	3/3 8/6	4110	4400	5160	5740							

Note: (1) *refers to rated capacity with dual front lines or wider lines;
 (2) 2.2.5t: free lifting height 457mm increase without backrest ;
 (3) 3.3.5t: free lifting height 520mm increase without backrest ;

Reliable special designed instrument

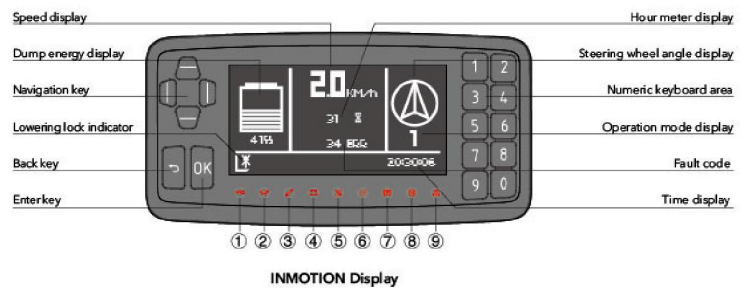
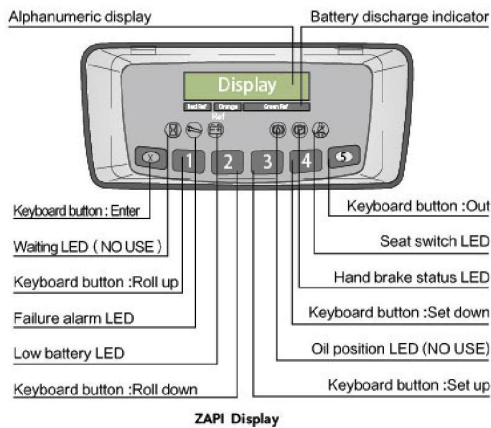

- ① DC type pump controller fault indicator
- ② Turtle indicator
- ③ Fault alarm light
- ④ Low electric quantity indicator
- ⑤ Lifting lock indicator
- ⑥ Seat indicator
- ⑦ Parking brake indicator
- ⑧ Neutral indicator
- ⑨ Warning light

Charger technology



- > High Efficiency
Charging efficiency higher than 95% meeting the requirements of energy saving and emissions reduction
- > Speediness
100% charging realized in 65mins at the soonest.
- > Compatibility
48 v / 80 v compatibility meeting the demand of different voltage levels
- > Safety
Built-in mis-connecting protection offering self isolating function under fault; Perfect fault self checking alarm facilitating users maintenance .

standard configuration

Wide view basic mast
Standard fork
li (iii) stage fork carriage
Backrest
Control valve
Battery
Standard seat
Overhead guard
Overhead guard rain cover
LCD dashboard
Pneumatic tyre (1-3t)
solid tyre (3.5t)
Traction pin
Tool box
LED lamp, strobe caution light
Rear driving handle with horn button

Carpet boom
Driver's cab
Lifting hook
Lifting boom
Tip-over fork
Back view mirror
Side shifting
Paper roll clamp
Warning light (rotating or buzzing)
solid tyre (1-3t)
Rear working light
Steel protection net
Multipurpose drum clamp
Load stabilizer
Widen fork carriage
Lengthening fork

Load pusher
Fork sleeve
Rotate clamp
Double tyre protection device
Auxiliary hydraulic valve component
Tilting/steering cylinder cover
Coloring tyre (white/green)
wide view two/three stage full free mast
Customised colour
Turn automatic deceleration function
Battery lifting sling
HELI smart fleet management system