

CQD14X2 / CQD16-18X1
3000-4000 lbs [1.4-1.8t]

48V Reach Truck
G Series AC Electric

LITON



* Details of specifications and equipment are based on information available at time of printing and may change without notice.

4320 NW 72 Ave, 33166 Miami, Florida – USA
(786) 340-6550 - sales@heliforklift-florida.com
www.heliforklift-florida.com

LIION

CQD14X2
GA2RLI/GB2RLI/GC2RLI

CQD16X1-GB2RLI

CQD18X1-GB2RLI



Operator comfort

- Rear padding and armrest help reduce fatigue
- Multifunction control is ergonomically designed and easy to use
- All controls are within easy reach to help reduce body strain
- Compartment floor is angled and spring suspended to reduce leg and back strain

Energy efficiency

- With an optimized hydraulic system, truck is more energy efficient
- All LED lights saves 80% of lighting energy
- Regenerative motor braking recycles more energy during braking cycles
- Programmable speed and acceleration settings can be set for maximum energy efficiency



Operator compartment provides comfort and efficient operation

Safety



Side stance improves operator's visibility both forward and backward



Automatic park brake applies when operator leaves the compartment or shuts forklift off



Programmable automatic deceleration in turns adds to safe operation



Warning lights and OPS system come standard

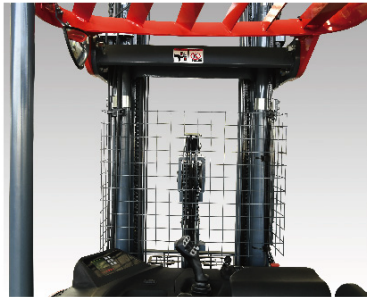

Great visibility for improved operation and safety

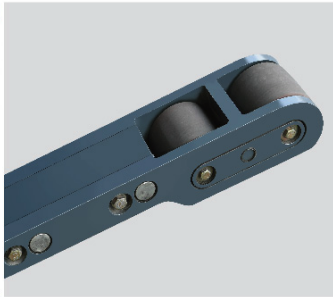

Bolt on outrigger boxes and easy change load wheels



Easy access to drive components

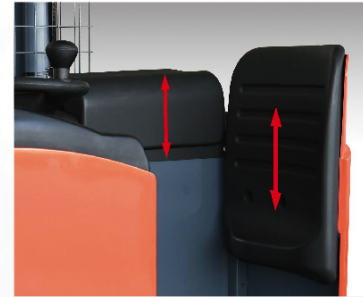

Adjustable backrest and armrest help reduce fatigue



Improved operator's view

- Large, rounded overhead guard is stylish and combined with strategically angled bars provides maximum visibility
- Newly designed, wide view mast with special chains enlarges the operator's view looking forward

Working efficiency

- Small turning radius makes steering flexible and easy
- With ZAPI control and AC powered motors, drive and lift systems can be programmed for maximum efficiency and performance
- The large battery capacity for longer single shift work operation
- With standard battery roller and side removal, battery change is quick and easy

Serviceability

- Side door gives easy access to drive motor and gearbox
- Chassis components are well laid-out and can be accessed with removable top and front covers

Wide view mast and pantograph

- Comes standard with side shift, tilt and reach functions
- Wide-view mast and pantograph maximize operator's view
- Lift cylinders have end stroke cushions for smooth stopping
- ZAPI controller provides in-transit buffers to ensure smooth lifting and lowering throughout the lifting cycle
- The controller also provides in-transit and end stroke buffer for the reach function

Overhead guard

- Overhead guard attaches directly to mast to eliminate front guard legs
- Optimally designed for maximum operator visibility
- Standard with left side guard leg for added strength
- Optional operator compartment guard leg for added safety



Helix's New Reach Trucks

Designed for productivity



ZAPI smart display & multi-function joystick

Designed for safety

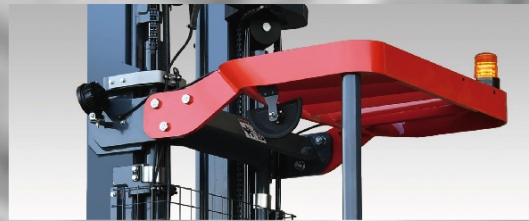

Standard lights, mesh finger guard & overhead guard with leg

Designed for serviceability



Easy to remove covers to access all electric and hydraulic components

Manufacturer's Data and Design Characteristics

Characteristics								HELI	
1.01	Manufacturer								
1.02	Model					CQD16X1		CQD18X1	
1.03	Configuration number					GB2RLI		GB2RLI	
1.04	Load capacity	Q	lb	kg	3500	1600	4000	1800	
1.05	Load center	C	in	mm	24	600	24	600	
1.06	Power mode						Electric Stand		
1.07	Operator Type								
1.08	Wheel base	L2	in	mm	55	1407	57	1457	
1.09	Voltage		v	v	48	48	48	48	
Tire									
2.01	Tire type				Polyurethane	Polyurethane	Polyurethane	Polyurethane	
2.02	Wheel number,drive/load/caster (X=drive wheel)				1×4/2	1×4/2	1×4/2	1×4/2	
2.03	Wheel size,load (diameter x length)		in	mm	Φ5×3.7	Φ127×95	Φ5×3.7	Φ127×95	
2.04	Wheel size,drive (diameter x length)		in	mm	Φ13×5.5	Φ330×140	Φ13×5.5	Φ330×140	
2.05	Wheel size,caster (diameter x length)		in	mm	Φ7.4×3	Φ178×76	Φ7.4×3	Φ178×76	
Dimensions									
3.01	Lift height (with standard mast)	H	in	mm	210	5330	210	5330	
3.02	Mast height,lowered	H1	in	mm	99	2526	99	2526	
3.03	Free lift	H8	in	mm	59	1490	59	1490	
3.04	Fork size (thickness x width x length)		in	mm	1.4×3.9×36.2	35×100×920	1.4×3.9×36.2	35×100×920	
3.05	Fork adjusting width	W4	in	mm	9.6~28.5	244~724	9.6~28.5	244~724	
3.06	Tilt (forward/backward)		deg	deg	3°/4°	3°/4°	3°/4°	3°/4°	
3.07	Fork sideshifting		in	mm	±2	±50	±2	±50	
3.08	Truck body length (fork excluded)	L	in	mm	71	1815	73	1865	
3.09	Truck body width	W	in	mm	43	1090	43	1090	
3.10	Straddle leg, inside width	W2	in	mm	33~51	845~1300	33~51	845~1300	
3.11	Straddle leg, outside width	W1	in	mm	47~59	1192~1492	47~59	1192~1492	
3.12	Fork carriage width	W3	in	mm	33	842	33	842	
3.13	Reach distance	S	in	mm	24	600	24	600	
3.14	Height of overhead guard	H7	in	mm	91	2320	91	2320	
3.15	Battery bottom clearance	H4	in	mm	7	180	7	180	
3.16	Straddle clearance	H5	in	mm	2	50	2	50	
3.17	Straddle height	H9	in	mm	5	130	5	130	
3.18	Step height	H6	in	mm	10	250	10	250	
3.19	Minimum turning radius	Wa	in	mm	67	1695	69	1745	
3.20	Rear overhang (drive wheel center to rear of frame)	L1	in	mm	10	252	10	252	
3.21	Front fork face to rear of frame distance	L4	in	mm	55	1396	55	1396	
3.22	Aisle width with pallet 48"Lx48"W (1200x1200)	Ast	in	mm	109	2771	111	2812	
3.23	Aisle width with pallet 40"Lx40"W (1000x1000)	Ast	in	mm	100	2550	102	2591	
Performance									
4.01	Travel speed loaded/unloaded		mph	km/h	6.5/7.3	10.5/11.8	6.5/7.3	10.5/11.8	
4.02	Lift speed loaded/unloaded		fpm	mm/s	65/100	330/510	65/100	330/510	
4.03	Lowering speed loaded/unloaded		fpm	mm/s	98/98	500/500	98/98	500/500	
4.04	Reach speed loaded/unloaded		fpm	mm/s	22/30	110/150	22/30	110/150	
4.05	Max.gadeability loaded/unloaded - 5 minute ratig		%	%	10/15	10/15	10/15	10/15	
Weight									
5.01	Total weight(without battery)		lb	kg	5400	2450	5644	2560	
5.02	Axle loading, no load (fomt/rear)		lb	kg	2844/4321	1290/1960	2954/4762	1340/2160	
5.03	Axle loading, loaded (fornt/rear)		lb	kg	7165/3527	3250/1600	7606/3968	3450/1800	
Battery									
6.01	Capacity at 6 hr.Discharge rate		kwh	Ah	19.4	404	19.4	404	
6.02	Maxmum battery weight		lb	kg	1800	820	2000	910	
6.03	Minimum battery weight		lb	kg	1635	742	1840	835	
6.04	Battery compartment dimension		in	mm	39.5×15.2×31.8	1005×388×810	39.5×16.8×31.8	1005×428×810	
Motor and controller									
7.01	Driving motor power		HP	kw	9.4	7	9.4	7	
7.02	Lifting motor power		HP	kw	20.1	15	20.1	15	
7.03	Steering motor power		HP	kw	0.8	0.6	0.8	0.6	
7.04	Type of driving control						MOSFET/AC		
7.05	Type of lifting control						MOSFET/AC		
7.06	Type of steering control						MOSFET/AC		
7.07	Transmission box						HELI special		
7.08	Service brake						Electric		
7.09	Hydraulic system working pressure		PSI	Mpa	3050	21	3050	21	

NOTE: For detailed information about battery, please contact your authorized HELI dealer.
These are "Zero Clearance" aisles in the table and require an additional 150mm or more to be added to provide for easier maneuvering.

Manufacturer's Data and Design Characteristics

Characteristics										
1.01	Manufacturer									
1.02	Model					CQD14X2				CQD14X2
1.03	Configuration number					GA2RLI				GC2RLI
1.04	Load capacity	Q	lb	kg	3000	1350		3000	1350	3000
1.05	Load center distance	C	in	mm	24	600		24	600	24
1.06	Power model					Lithium Battery				Lithium Battery
1.07	Driving model					Stand				Stand
1.08	Wheel base	L2	in	mm	61.3	1557		62.7	1593	65.2
1.09	Voltage		v	V		48		48	1593	48
Tire										
2.01	Tyre type					PU				PU
2.02	Wheel nuber,drive/load/caster(X=drive wheel)					1x/4/2				1x/4/2
2.03	Wheel size,load		in	mm	Φ5×3.7	Φ127×95		Φ5×3.7	Φ127×95	Φ5×3.7
2.04	Wheel size,drive		in	mm	Φ13×5.5	Φ330×140		Φ13×5.5	Φ330×140	Φ13×5.5
2.05	Wheel size,caster		in	mm	Φ7.4×3	Φ178×76		Φ7.4×3	Φ178×76	Φ7.4×3
Dimensions										
3.01	Lift height	H	in	mm	210	5330		210	5330	210
3.02	Free lift	H1	in	mm	99	2526		99	2526	99
3.03	Mast height,lowered	H8	in	mm	59	1490		59	1490	59
3.04	Fork size,thickness/width/length	s/e/l	in	mm	1.4×3.9×36.2	35×100×920		1.4×3.9×36.2	35×100×920	1.4×3.9×36.2
3.05	Fork adjusting width	W4	in	mm	9.6~28.5	244~724		9.6~28.5	244~724	9.6~28.5
3.06	Tilt		deg	deg		3°/4°		3°/4°		3°/4°
3.07	Fork sideshifting		in	mm	±2	±50		±2	±50	±2
3.08	Truck body length(fork excluded)	L	in	mm	77	1954		78	1990	81
3.09	Truck body width	W	in	mm	42.9	1090		42.9	1090	42.9
3.10	Fork carriage width	W3	in	mm	33	842		33	842	33
3.11	Reach distance	S	in	mm	43	1080		43	1080	43
3.12	Height of overhead guard	H7	in	mm	91	2320		91	2320	91
3.13	Battery bottom clearance	H4	in	mm	7.1	180		7.1	180	7.1
3.14	Straddle clearance	H5	in	mm	2	50		2	50	2
3.15	Straddle height	H9	in	mm	5.1	130		5.1	130	5.1
3.16	Step height	H6	in	mm	9.8	250		9.8	250	9.8
3.17	Minimum turning radius	Wa	in	mm	72	1838		74	1874	76
3.18	Drive wheel center to truck body rear distance	L1	in	mm	9.9	252		9.9	252	9.9
3.19	Fork front to truck body rear distance	L4	in	mm	60	1529		62	1565	64
3.20	Aisle width with pallet 1200Lx1200w	Ast	in	mm	116	2935		117	2971	119
3.21	Aisle width with pallet 1000Lx1000w	Ast	in	mm	107	2713		108	2749	111
Performance										
4.01	Travelling speed,with/without load		mph	km/h	6.2/6.8	10/11		6.2/6.8	10/11	6.2/6.8
4.02	Lifting speed,with/without load		fpm	mm/s	65/100	330/510		65/100	330/510	65/100
4.03	Lowering speed,with/without load		fpm	mm/s	98/98	500/500		98/98	500/500	98/98
4.04	Reach speed,with/without load		fpm	mm/s	22/30	110/150		22/30	110/150	22/30
4.05	Maximum climb capability,with/without load		%	%		10/15		10/15		10/15
Weight										
5.01	Total weight(without battery)		lb	kg	6063	2750		6107	2770	6151
5.02	Axle loading, no load (fornt/rear)		lb	kg	3040/4897	1379/2221		3182/5125	1443/2325	3374/5277
5.03	Axle loading, loaded (fornt/rear)		lb	kg	6635/4278	3010/1940		6860/4423	3112/2006	6976/4651
Battery										
6.01	Battery voltage/capacity k5		kwh	Ah	19.4	404		26	542	26
6.02	Minimum battery weight		lb	kg	2350	1066		2800	1270	3100
6.03	Minimum battery weight		lb	kg	1850	839		2200	998	2500
6.04	Battery department size		in	mm	39.5×16.8×31.8	1005x428x810		39.5×18.3×31.8	1005x465x810	39.5×20.7×31.8
Motor and controller										
7.01	Driving motor power		HP	kw	9.4	7		9.4	7	9.4
7.02	Lifting motor power		HP	kw	20.1	15		20.1	15	20.1
7.03	Steering motor power		HP	kw	0.8	0.6		0.8	0.6	0.8
7.04	Type of driving control					MOSFET/AC		MOSFET/AC		MOSFET/AC
7.05	Type of lifting control					MOSFET/AC		MOSFET/AC		MOSFET/AC
7.06	Type of steering control					MOSFET/AC		MOSFET/AC		MOSFET/AC
7.07	Transmission box					HELI special		HELI special		HELI special
7.08	Service brake					Electric		Electric		Electric
7.09	Parking Brake					Automatic		Automatic		Automatic
7.10	Hydraulic system working pressure		PSI	Mpa	3050	21		3050	21	3050

NOTE: For detailed information about battery,please contact your authorized HELI dealer.
 These are "Zero Clearance" aisles in the table and require an additional 150mm or more to be added to provide for easier maneuvering.

AST: Right angle stacking aisle width
 a: Clearance a=150mm

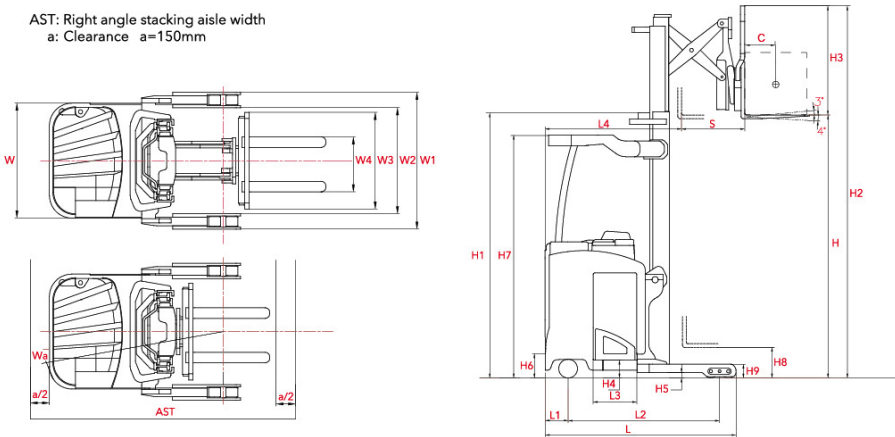

OPTIONAL STRADDLE WIDTH

Straddle inside width W2	in/mm	33.2/845	36/915	38/966	39.6/1008(standard)	42/1068	44/1119	46/1170	48/1221	50/1272
Straddle outside width W1	in/mm	44.7/1137	47.5/1207	49.5/1258	51.1/1300(standard)	53.5/1360	55.5/1411	57.5/1462	59.5/1513	61.5/1564

WIDE VIEW FULL FREE 3-STAGE MAST

Mast model	Fork Height		Free lift		Mast height		Load Capacity at 24" Load Center						Service Weight					
	CQD14X2		CQD14X2		CQD14X2		CQD14X2-GA2RLI		CQD14X2-GB2RLI		CQD14X2-GC2RLI		CQD14X2-GA2RLI		CQD14X2-GB2RLI		CQD14X2-GC2RLI	
	in	imm	in	mm	in	mm	lb	kg	lb	kg	lb	kg	lb	kg	lb	kg	lb	kg
ZSM502	198	5025	55	1390	96	2426	2976	1350	2976	1350	2976	1350	7893	3580	8263	3748	8607	3904
ZSM533	210	5330	59	1490	99	2526	2976	1350	2976	1350	2976	1350	7937	3600	8307	3768	8651	3924
ZSM610	240	6095	69	1745	109	2781	2646	1200	2646	1200	2646	1200	8091	3670	8461	3838	8805	3994
ZSM685	270	6855	79	2000	120	3036	2205	1000	2205	1000	2205	1000	8201	3720	8572	3888	8915	4044
ZSM762	300	7620	90	2285	131	3321	1764	800	1984	900	1984	900	8356	3790	8726	3958	9070	4114

WIDE VIEW FULL FREE 3-STAGE MAST

Mast model	Fork Height h3 (in)(mm)		Free lifting height h3 (in)(mm)		Mast height h1 (in)(mm)		Load Capacity at 24" Load Center (lb) (kg)				Service Weight (lb) (kg)					
	CQD16X1		CQD18X1		CQD16X1		CQD16X1		CQD18X1		CQD16X1		CQD18X1			
	in	mm	in	mm	in	mm	lb	kg	lb	kg	lb	kg	lb	kg		
ZSM502	198	5025	55	1390	95	2413	95	2413	3527	1600	3968	1800	7374	3345	7672	3480
ZSM533	210	5330	59	1490	99	2526	99	2526	3527	1600	3858	1750	7419	3365	7716	3500
ZSM610	240	6095	69	1745	109	2781	109	2781	3527	1600	3858	1750	7573	3435	7871	3570
ZSM685	270	6855	79	2000	120	3036	120	3036	2425	1100	2866	1300	7683	3485	7981	3620
ZSM762	300	7620	90	2285	131	3321	131	3321	2094	950	2425	1100	7837	3555	8135	3690

ZAPI intelligent display provides vital information such as speed and battery discharge status and is used to customize performance parameters



ZAPI intelligent display

Standard configuration

- 36V electric system
- All AC motors with ZAPI controls
- 218" (5330mm) 3-stage full free lift mast
- Integral pantograph with tilt and sideshift
- Standard forks
- Load backrest
- Polyurethane tires
- Electromagnetic proportional valve
- Battery rollers
- Overhead guard
- LED combined display
- Front work light
- LED warning light
- Automatic steering slow down
- Electromagnetic, regenrative service brake
- Automatic park brake
- Low noise gear pump
- DC/DC converter

Optional device

- 48V electric system
- Additional mast heights - 198-300" (5025-7620mm)
- Lifting height pre-selector
- Monitoring system
- Additional batteries including Hoppecker and FAAM
- Battery charger
- Custom paint
- Additional operator protection guard
- Battery loading and unloading cart

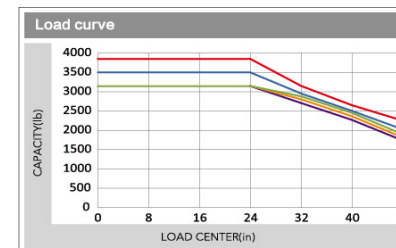

NOTE: The vertical axis is the load capacity, and the horizontal axis is the load center which is calculated from the front face of the forks to the load center of gravity. Capacity curves shown are for a standard mast at zero degree tilt with standard forks. Changing mast tilt, using non-standard forks or loading large goods can affect load capacity. This chart can be used to estimate load capacity at various load centers for standard masts. Contact HELI for specific load ratings for your situation.