

# OPSM

## Light Type Order-picking Truck

### Characteristics

1. The width of the passageway is only 1 meter and the turning passageway is 2 meters. The truck is compact, and it can easily pass through the workshop aisle and low doors, which can widely be used in retail, storage center, library and other narrow spaces;
2. The truck features electric lifting and travelling. When the lifting height is more than 0.5m, the truck will automatically decelerate which not only saves time and labor but also be safe and stable;
3. The front tray can adjust its height freely to realize the convenient storage of large and small goods;
4. The truck adopts double safety protection measures. When the driver's hands or feet extend out of the truck body, the truck will stop driving to avoid pinching the driver;
5. Independent fingertip control system, including control on acceleration, lifting, tortoise speed, emergency stop is comfortable for operation.



### Product characteristics table

Product characteristics table			
		Characteristics	
1.1	Model		OPSM
1.2	Operator type		Stand-on
1.3	Load capacity of loading tray	kg	90
1.4	Load capacity of loading dock	kg	150
1.5	Load capacity of cab	kg	130
1.6	Service weight with battery	Kg	750/770
1.7	Wheel base	y(mm)	1145
Wheels			
2.1	Wheels type		PU
2.2	Wheels size(Front)	mm	180X50
2.3	Wheels size(Rear)	mm	250X60
2.4	Wheel quantity (Front/Rear)		2/2X
2.5	Front wheel base of bearing	mm	600
2.6	Rear wheel base of driving	mm	680
Dimension			
3.1	Pallet adjustment height range	H2(mm)	260
3.2	Lifting height of platform	H12(mm)	3000
3.3	Pick up height	H13(mm)	≈5000
3.4	Pallet size	mm	700X500
3.5	Overall height	H1(mm)	1590
3.6	Overall length	L1(mm)	1500
3.7	Overall width	b1(mm)	750
3.8	Turning radius	Wa(mm)	1300
3.9	Aisle width	Ast(mm)	1750
3.10	Ground clearance,center of wheelbase	m2	65
Performance			
4.1	Travel speed,laden/unladen	Km/h	4.5
4.2	Lift speed, laden/unladen	m/s	0.14
4.3	Lowering speed, laden/unladen	m/s	0.13
4.4	Max.gradeability,laden/unladen		5%
4.5	Type of service brake		Electromagnetic brake
Motor and batter			
5.1	Drive motor power,60min	Kw	0.5
5.2	Lifting motor power,15min	Kw	2.2
5.3	Battery voltage/capacity,K5	V/Ah	24V/88(220)Ah
5.4	Battery size(length X Wigth X Height)		260X168(180)X217(275)
5.5	Battery weight		26X2(35X4)
Others			
6.1	Type of drive control		DC
6.2	Sound pressure level at driver' s ear	Db(A)	≤70
6.3	Steering type		Electronic steering

### OPSM Dimensions

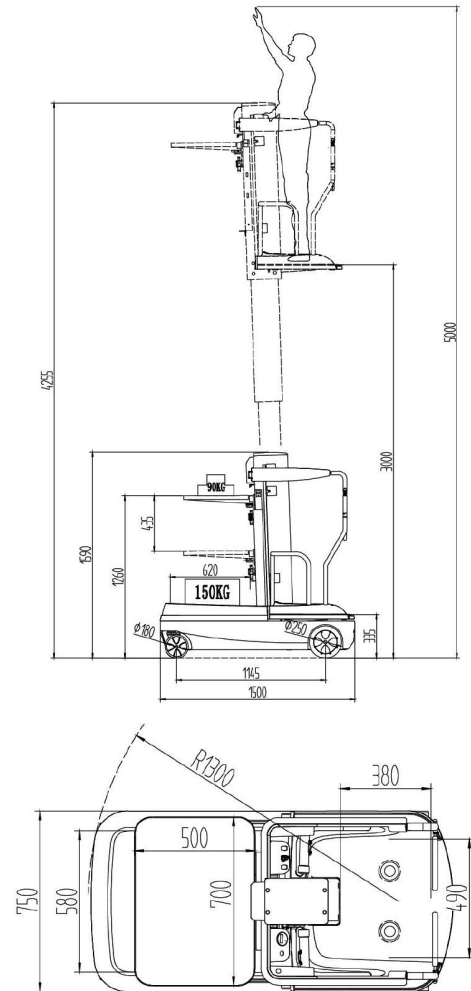

The picking height can reach to 5m, easy for picking-up or storage of items at 3rd rack level, sprice tag exchanged or ceiling upholster and light fixing.

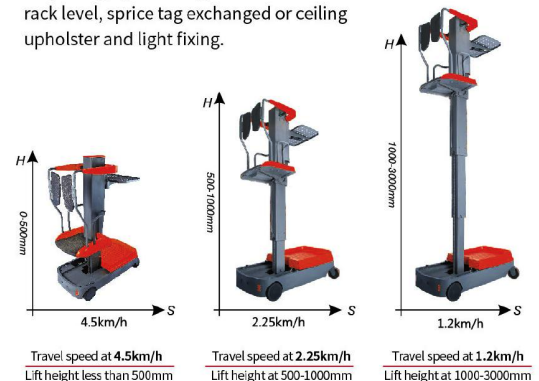

Design&Print:Fokell Printing 20200821

